

ATLAS KOMPAKT

Excavator AC 25UF

Operating Weight	2.65 t
Engine power	14.6 kW / 2400 rpm
Engine brand	YANMAR
Standard Bucket Capacity	0.08 m ³
Max. Digging Depth	2.84 m



Parameter

 www.atlas-kompakt.com

ENGINE

Brand	Yanmar
Model	3TNV80F - SPSU
Type	3-cylinder water cooled
Displacement	1267 cm ³
Power	14.6 kW / 2400 rpm

ELECTRIC SYSTEM

Nominal Voltage	12 V
Batteries	63 Ah
Alternator	12 V - 40 A
Starter	12 V - 1.7 kW

DRIVE

Max. Travel Speed (2ns/1st)	4.1/2.3 km/h
Gradeability	30°
Max. Traction	30.7 kN

UNDERCARRIAGE

Undercarriage Width	1500 mm
Shoe Width	300 mm
Length to Center of Rollers	1560 mm
Track Length	1990 mm
Track Height	475 mm

BULLDOZING BOARD

Independent Moving, Controlled By The Gear Shift Lever	
Length X Width	1500x325 mm
Max. Lifting Height	330 mm
Max. Cutting Depth	320 mm

DIMENSIONS

Counterweight Clearance	525 mm
Tail Swing Radius	765 mm
Shipping Length	4140 mm
Shipping Width	1500 mm
Shipping Height	2455 mm

WORKING RANGES

Max. Cutting Height	4355 mm
Max. Loading Height	3010 mm
Max. Digging Depth	2840 mm
Max. Vertical Wall Digging Depth	2580 mm
Max. Digging Reach	4775 mm
Max. Reach at Ground Level	3085 mm
Bucket Digging Force	24 kN
Stick Digging Force	14 kN
Ground Pressure	24.5 kPa
Swing Speed	8.8 rpm

CAPACITY

Fuel Tank	26 L
Hydraulic Oil Tank	24 L

HYDRAULIC SYSTEM

Main Pumps	
Type	2 variable pumps, 1 gear pump
Displacement	2x28.8 + 191.2 + 6.5
Working Pressure	2x21.5+18 MPa

Working Ranges

Excavator AC 25UF

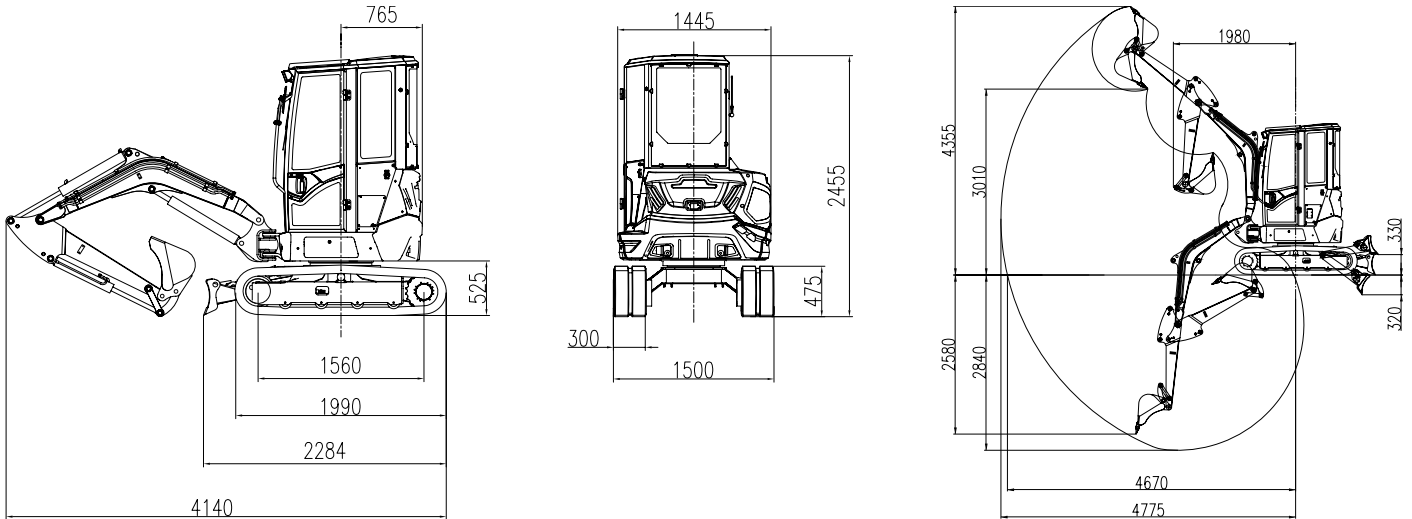

Load Capacity

A (m)	MAX	3.5 m		3.0 m		2.5 m		2.0 m		
B (m)	Front (kg)	Side (kg)	Front (kg)	Side (kg)	Front (kg)	Side (kg)	Front (kg)	Side (kg)	Front (kg)	Side (kg)
3.0	469.00*	404.30	—	—	469.00*	404.30	—	—	—	—
2.5	497.70*	350.70	—	—	512.10*	424.90	—	—	—	—
2.0	536.00*	313.50	550.40*	445.60	536.00*	424.90	670.00*	515.70	—	—
1.5	540.80*	288.80	564.70*	440.10	612.60*	420.80	813.60*	528.10	—	—
1.0	555.10*	280.50	583.90*	429.10	703.50*	396.10	875.80*	503.30	—	—
0.5	574.30*	276.40	617.40*	407.10	703.50*	371.30	961.90*	470.30	—	—
0.0	612.60*	276.40	650.90*	396.10	813.60*	358.90	947.60*	449.70	1292.20*	598.20
-0.5	650.90*	309.40	—	—	756.10*	367.20	861.40*	474.40	1196.40*	577.60
-1.0	679.60*	363.10	—	—	679.60*	375.40	823.10*	466.20	1005.00*	573.50

Notes:

- 1) Load with * is limited by hydraulic capacity and based on ISO 10567. Rated loads do not exceed 87% of hydraulic capacity.
- 2) Load without * is limited by tipping load and based on ISO 10567. Rated loads do not exceed 75% of tipping load.

